

aus Stahl

Scheibendicke = 4 mm

bei 6 mm ab $z = 51$

bei 8 mm ab $z = 46$

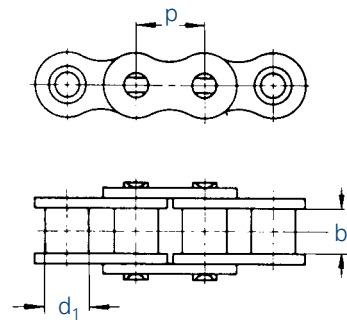
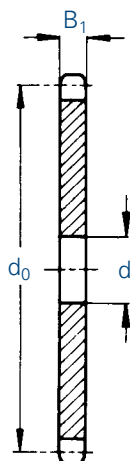

Zähne- zahl	445 (04)		450 (05 B-1)		455 (06 B-1)	
	p	b_1	p	b_1	p	b_1
z	d_0	d	d_0	d	d_0	d
	mm	mm	mm	mm	mm	mm
11	21,30	6	28,40	8	33,81	8
12	23,18	6	30,91	8	36,80	8
13	25,07	8	33,43	8	39,80	8
14	26,96	8	35,95	8	42,81	8
15	28,86	8	38,48	8	45,81	8
16	30,75	8	41,01	8	48,82	10
17	32,65	8	43,54	8	51,84	10
18	34,55	8	46,07	8	54,85	10
19	36,45	8	48,60	8	57,87	10
20	38,36	8	51,14	8	60,89	10
21	40,26	8	53,68	8	63,91	10
22	42,16	8	56,21	8	66,93	10
23	44,06	8	58,75	8	69,95	10
24	45,97	8	61,29	8	72,97	10
25	47,87	8	63,83	8	76,00	10
26	49,78	8	66,37	10	79,02	10
27	51,68	8	68,91	10	82,05	10
28	53,59	8	71,45	10	85,07	10
29	-	-	73,99	10	88,10	10
30	57,40	8	76,53	10	91,12	10
31	-	-	79,08	10	94,15	12
32	61,21	8	81,62	10	97,18	12
33	63,12	8	84,16	10	100,20	12
34	65,03	8	86,70	10	103,23	12
35	66,93	8	89,25	10	106,26	12
36	68,84	8	91,79	10	109,29	12
37	70,75	8	94,33	10	112,31	12
38	72,65	8	96,88	10	115,34	12
39	-	-	99,42	10	118,37	12
40	76,47	8	101,96	10	121,40	12
45	86,01	10	114,68	12	136,55	16
57	108,92	12	145,22	14	172,91	16
65	124,19	14	165,59	16	197,15	20

aus Stahl

Scheibendicke = 4 mm

331 (081) ab z = 41

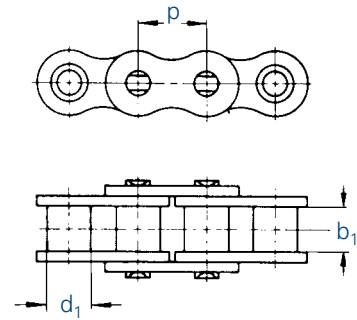
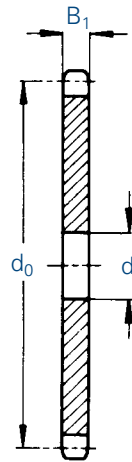

Zähne- zahl	331 (081)		332		462 (08 B-1)		501 (10 B-1)		
	p	b_1	p	b_1	p	b_1	p	b_1	
z	d_0	d	d_0	d	d_0	d	d_0	d	
	Ind.	mm	mm	mm	mm	mm	mm	mm	
11		45,08	8	45,08	8	45,08	10	56,35	10
12		49,07	8	49,07	8	49,07	10	61,34	10
13		53,07	8	53,07	8	53,07	10	66,34	10
14		57,07	8	57,07	8	57,07	10	71,34	10
15		61,08	8	61,08	8	61,08	10	76,35	10
16		65,10	10	65,10	10	65,10	10	81,37	12
17		69,12	10	69,12	10	69,12	10	86,39	12
18		73,14	10	73,14	10	73,14	10	91,42	12
19		77,16	10	77,16	10	77,16	10	96,45	12
20		81,18	10	81,18	10	81,18	10	101,48	12
21		85,21	10	85,21	10	85,21	12	106,51	12
22		89,24	10	89,24	10	89,24	12	111,55	12
23		93,27	10	93,27	10	93,27	12	116,59	12
24		97,30	10	97,30	10	97,30	12	121,62	12
25		101,33	10	101,33	10	101,33	12	126,66	12
26		105,36	12	105,36	12	105,36	16	131,70	16
27		109,40	12	109,40	12	109,40	16	136,74	16
28		113,43	12	113,43	12	113,43	16	141,79	16
29		-	-	117,46	12	117,46	16	146,83	16
30		121,50	12	121,50	12	121,50	16	151,87	16
31		-	-	125,53	12	125,53	16	156,92	16
32		129,57	12	129,57	12	129,57	16	161,96	16
33		133,61	12	133,61	12	133,61	16	167,01	16
34		137,64	12	137,64	12	137,64	16	172,05	16
35		141,68	12	141,68	12	141,68	16	177,10	16
36		145,72	16	145,72	16	145,72	16	182,14	20
37		149,75	16	149,75	16	149,75	16	187,19	20
38		153,79	16	153,79	16	153,79	16	192,24	20
39		157,83	16	157,83	16	157,83	16	197,29	20
40		161,87	16	161,87	16	161,87	16	202,35	20
45		182,06	16	182,06	16	182,06	20	227,58	20
57		230,54	20	230,54	20	-	-	288,18	25
65		-	-	262,87	20	262,87	25	328,58	25

aus Stahl

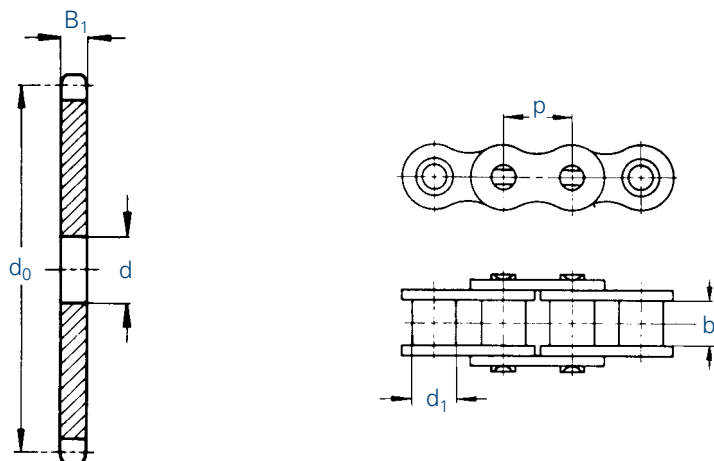

Zähne- zahl	513 (12 B-1)		548 (16 B-1)		563 (20 B-1)		596 (24 B-1)		
	p	b_1	p	b_1	p	b_1	p	b_1	
z	d_0	d	d_0	d	d_0	d	d_0	d	
	Ind.	mm	mm	mm	mm	mm	mm	mm	
11		67,62	14	90,16	15	112,69	16	135,23	20
12		73,60	14	98,14	15	122,67	20	147,21	20
13		79,60	14	106,14	15	132,67	20	159,21	20
14		85,61	14	114,15	15	142,68	20	171,22	20
15		91,62	14	122,17	15	152,71	20	183,25	20
16		97,65	14	130,20	19	162,74	25	195,29	25
17		103,67	14	138,23	19	172,79	25	207,35	25
18		109,71	14	146,27	19	182,84	25	219,41	25
19		115,74	14	154,32	19	192,90	25	231,48	25
20		121,78	14	162,37	19	202,96	25	243,55	25
21		127,82	16	170,42	20	213,03	25	255,63	25
22		133,86	16	178,48	20	223,10	25	267,72	25
23		139,90	16	186,54	20	233,17	25	279,81	25
24		145,95	16	194,60	20	243,25	25	291,90	25
25		151,99	16	202,66	20	253,32	25	303,99	25
26		158,04	16	210,72	20	263,40	25	-	-
27		164,09	16	218,79	20	273,49	25	328,19	30
28		170,14	16	226,86	20	283,57	25	-	-
29		176,20	16	234,93	20	293,66	25	352,39	30
30		182,25	16	243,00	20	303,75	25	364,50	30
31		188,30	20	251,07	25	313,83	25	-	-
32		194,35	20	259,14	25	323,92	25	388,71	30
33		200,41	20	267,21	25	334,01	25	-	-
34		206,46	20	275,29	25	344,11	25	-	-
35		212,52	20	283,36	25	354,20	25	425,04	30
36		218,57	20	291,43	25	364,29	25	-	-
37		224,63	20	299,51	25	374,38	25	-	-
38		230,69	20	307,58	25	384,48	25	461,38	30
39		236,74	20	315,66	25	394,57	25	-	-
40		242,80	20	323,74	25	404,67	25	485,60	30
45		273,09	25	364,12	25	455,16	30	546,19	30
57		345,81	25	461,08	30	576,35	30	691,63	30
65		394,30	25	525,73	30	657,17	30	788,60	40